

Translation
Principles of testing and certification of face shields for electrical work

Status as of: 2019-06, Rev. 01

Principles of testing
face shields for electrical
work
GS-ET -29 E

„ETEM“ Department
Electrical engineering testing and
certification body in DGUV Test
Gustav-Heinemann-Ufer 130
50968 Cologne, Germany

GS-ET-29 E

Preliminary remarks

These Principles of testing serve as verification that the requirements of the German Product Safety Act (ProdSG) have been complied with.

These supplemental requirements compliment the requirements from EN 166:2001 in order to achieve conformity with PPE Regulation (EU) 2016/425.

Remark 1:

The testing of thermal protection according to Sec. 4.2 of these Principles of testing is based upon DIN EN 61482-1-2.

Remark 2:

The distance between the electrode axis and calorimeter No. 3 according to Fig. 7 of these Principles of testing was set at 350 mm based on practical experience gained through work performed on live components within the immediate field of vision.

These principles will be revised and supplemented periodically in consideration of knowledge gained in the area of occupational safety and to keep pace with technical progress.

Changes with respect to Edition 2011-05:

- Change to the Preliminary remarks; Reference to the PPE Regulation (EU) 2016/425
- Sec. 1.1: Limitation inserted
- Previous Sec. 1.2 „Testing and certification process“ deleted
- Sec. 3.2: Supplement to „Risk assessment“, „EC Declaration of Conformity“
- Sec. 3.3: Supplement to the test specimens
- Sec. 4.2.11.2: Supplement to the Test specimens
- Sec. 4.2.11.5: Supplement to the dispersion of electric arc shots over the test specimen
- Sec. 4.3: Supplement to CE marking with identification number, Electric fault arc symbol; Supplement: Testing of marking durability
- Sec. 4.4: Supplement to the information regarding PPE Regulation (EU) 2016/425; Supplement: Detailed information regarding safety helmets; Explanation regarding the Electric fault arc symbol; Deletion: Information regarding minimum lighting and replacement with specification of a process for colour recognition
- New Section: 4.5
- Annex 1 Electric fault arc symbol
- Annex 2 Additional information regarding colour recognition
- Annex 3 Information regarding contract preparation: new
- Update of standard specifications
- Editorial changes

Rev.: 01

Appendix 2, page 29: Editorial change: Replacement of sentence 2+3 for light transmission class 0 with the corresponding sentences for light transmission class 1; for light transmission class 2: Replacement of the word "nevertheless" with "in any case".

***This is the English translation of the German test principle.
The German original version is obligatory.***

Table of Contents		Page
1	General	5
1.1	Scope of application	5
1.2	Test specifications	5
1.3	Validity	5
2	Terms	6
2.1	Electrician face shield	6
2.2	Torso	6
2.3	VLT	6
3	Requirements and tests	6
3.1	General specifications	6
3.2	Documents to be submitted	6
3.3	Test specimens	7
4	Additional requirements/Tests	7
4.1	Additional optical requirements	7
4.1.1	Visible light transmittance	7
4.1.1.1	Requirements	7
4.1.1.2	Testing	8
4.1.2	Diffused light	8
4.1.3	Resistance to UV radiation	8
4.2	Thermal protection	9
4.2.1	Test apparatus	9
4.2.2	Test chamber	9
4.2.3	Torso	9
4.2.4	Test head with calorimeter	9
4.2.4.1	Sensor installation	9
4.2.4.2	Sensor response	10
4.2.5	Electrical supply and electrodes	10
4.2.5.1	Electric test circuit	10
4.2.5.2	Test circuit control	10
4.2.5.3	Electrodes	10
4.2.5.4	Fuse wire	11
4.2.6	Electric test arc characteristics	11
4.2.7	Data acquisition system	11

Table of Contents		Page
4.2.8	Preparing the test specimen	12
4.2.9	Calibration	12
4.2.9.1	Measurement chain for temperature acquisition	12
4.2.9.2	Calibration of the electric test circuit and performing the test	12
4.2.9.3	Confirmation of test apparatus settings	13
4.2.9.4	Preparing and conditioning the chamber	13
4.2.10	Maintenance and care of the test apparatus	13
4.2.10.1	Care of the sensor surface	13
4.2.10.2	Care of the torso and test head	13
4.2.11	Test procedures	13
4.2.11.1	Test apparatus	13
4.2.11.2	Number of test specimens	13
4.2.11.3	Test parameters	13
4.2.11.4	Test conditions and initial temperature	13
4.2.11.5	Performing the test	15
4.2.11.6	Evaluation of measurement results	15
4.2.11.7	Test results	16
4.3	Additional marking & identification	17
4.4	User information	17
4.5	External materials	19
4.5.1	Plastic components	19
4.5.2	Textile/leather components	19
4.6	Test setups	20
Annex 1		26
Annex 2		27
Annex 3		28

1 **General**

1.1 **Scope of application**

These supplemental requirements apply to electrician face shields worn when working where a risk of electric arcing exists.

These Principles of testing do not apply to electrician face shields that cover all areas of the head and the entire neck (360° coverage).

1.2 **Test specifications**

Applicable standards

DIN EN 166 (2002-04)	Personal eye-protectors – Requirements –
DIN EN ISO 9151 (2017-05)	Protective clothing against heat and flames – Determination of heat transmission with exposure to flame
DIN EN 60584-1 (2014-07)	Thermocouples – Part 1: EMF specifications and tolerances
DIN EN 61482-1-2 (2015-08)	Live working – Protective clothing against the thermal hazards of an electric arc – Part 1-2: Test methods – Method 2: Determination of arc protection class of material and clothing by using a constrained and directed arc (box test)
DIN EN ISO 11664-1 (2011-07)	Colorimetry – Part 1: CIE standard colorimetric observers
DIN EN ISO 11664-2 (2011-07)	Colorimetry – Part 2: CIE standard illuminants

Normative references in these Principles of testing always relate to the edition of the respective standard as listed in this section.

1.3 **Validity**

Principles of testing, GS-ET-29, Edition 2019-06 replaces Edition 2011-05. Edition 2011-05 remained valid until 01 Feb. 2020.

2 **Terms**

2.1 **Electrician face shield**

The electrician face shield is an item of personal protective equipment worn over the facial area and in combination with headgear.

It is comprised of a transparent protective shield or visor, which is either attached to a frame or bordered in textile material.

2.2 **Torso**

Torso is a replication of the upper part of the human body, comprised of a plate made of non-flammable, non-metallic material.

2.3 **VLT (Visible light transmittance)**

Specification of the Visible light transmittance (VLT) considers the spectral perception of brightness by the average human eye for photopic vision in accordance with DIN EN ISO 11664-1.

3 **Requirements and tests**

3.1 **General specifications**

Insofar as it has not been set forth in the individual test sections, testing is to be carried out at an ambient temperature of 20° C \pm 5 K and a relative humidity of 30 to 85 %.

Testing shall be conducted according to the rating data prescribed by the manufacturer. The values determined must not diverge from the rating data by more than \pm 5 %.

3.2 **Documents to be submitted**

The following technical documentation is required for testing:

- User information including technical specifications
- Parts lists
- Data sheets for the materials used
- Product drawings including dimensions

- Manufacturing instructions
- Risk assessment in accordance with the PPE Regulation, Annex III, b.
- EC Declaration of Conformity

3.3 Test specimens

Four specimens of each electrician face shield, including headgear, as well as three specimens of the visor panel (200 x 200 mm) are required for testing.

The testing of electrician face shields used solely in conjunction with a safety helmet requires either two helmets with the manufacturer's prescribed minimum and maximum distances from the filter to the forehead (inner surface of the helmet sweatband) or four safety helmets of a defined helmet type.

4 Additional requirements/Tests

4.1 Additional optical requirements

4.1.1 Visible light transmittance (380 nm to 780 nm)

4.1.1.1 Requirements

Visible light transmittance¹ VLT is to be determined on at least three test specimens² using the following light sources:

- Standard illuminant
- Fluorescent lamp
- White light – LED

Protective shields are allocated into the following Light transmittance (LT) classes according to Standard illuminant source D65:

Class 0:

Visible light transmittance VLT (D65) $\geq 75 \%$
(no details required in the User information)

Class 1:

Visible light transmittance VLT (D65) $50 \% \leq \text{VLT (D65)} < 75 \%$
(limitations must be defined in the User information)

¹ Test setup, refer to Fig. 3

² Each protective shield can be reused with each light source.

Class 2:

Visible light transmittance VLT (D65) < 50 % (limitations must be defined in the User information)

4.1.1.2 Testing

Measurement takes place using a spectrometer featuring at least a 5 nm resolution (Remark: in contrast to a 1 nm resolution, the MU increases by 1 %), ideally allowing 1 nm incremental steps. A test setup for determining the three Visible light transmittance VLT values (standard illuminant A, fluorescent lamp, white light – LED) is depicted in Fig. 3.

The visor panel must be at least 200 x 200 mm. VLT is to be determined from three different positions for both the right and the left eyes. The proposed measuring field is depicted in Fig. 4. The test specimen is to be mounted flat onto the test setup.

Three test series are to be carried out per measuring field and light source, whereby the respective mean value shall be used to assess VLT. The degree of measurement uncertainty must be specified.

Manufacturer specifications for each light source must lie within a tolerance of (+3 %/-5 %) to the test results ascertained.

4.1.2 Diffused light

DIN EN 166, Sec. 7.1.2.3 is applicable for visor panels in Electric arc class 1.

DIN EN 166, Sec. 7.1.2.3 with the highest welding filter value is applicable for visor panels in Electric arc class 2.

4.1.3 Resistance to UV radiation

DIN EN 166, Sec. 7.1.5.2 is applicable for visors in Electric arc class 1.

DIN EN 166, Sec. 7.1.5.2 for welding filters is applicable for visor panels in Electric arc class 2.

If the LT Class as per Sec. 4.1.1.1 of these Principles of testing changes due to radiant exposure, then this must be identified in the markings and the information necessary for marking as set forth in Sec. 4.4 of these Principles of testing must be inserted into the User information.

4.2 Thermal protection (electric arc testing)

4.2.1 Test apparatus

The test apparatus must comprise the following elements:

- Test chamber
- Torso
- Test head with calorimeter
- Electrical supply
- Data acquisition system

4.2.2 Test chamber

The test chamber conforming to Fig. 5 must be made of non-conductive, heat-resistant materials (e.g. plaster).

4.2.3 Torso

A torso in the form of a plate ($H = 500$ mm, $W = 600$ mm, $D = \text{min.}10$ mm) made of non-flammable, non-metallic material is to be used for testing. The torso is to be configured in such a manner that it will remain in position for the duration of the electric arc.

4.2.4 Test head with calorimeter

The test head corresponds approximately to the 50 percentile adult male and is made of non-flammable, non-metallic material. Nominal dimensions and details regarding construction are specified in Fig. 6.

4.2.4.1 Sensor installation

The sensor having a diameter of 60 mm is comprised of an insulating board and a calorimeter. The calorimeter is comprised of a round copper disc made of electrolytic copper with a diameter of 40 mm and a mass of 18 g, as well as a Type T thermocouple (copper-constantan) in accordance with DIN 9151.

The thermocouple element made of copper-constantan wire (Type T according to DIN EN 60584-1) shall be attached in such a manner that the constantan wire is located at the centre, while the copper wire is located outside the centre of the disc. The disc is embedded in an insulating board.

The sensor shall be mounted flush with surface of the test panel. The surface of the heat-absorbing copper disc must be coated with a thin layer of optically black colour.

4.2.4.2 Sensor response

The conversion of sensor measurement values from temperature rise in °C to thermal energy (incident energy) in units of kJ/m² shall be calculated by multiplying the delta temperature values by a constant factor of 5.52 kJ/m² °C.

NOTE: *The constant factor is based on an average value for the copper thermal capacity $C_p = 0.385 \text{ J/g } ^\circ\text{C}$ (80 °C) in the tested temperature range.*

4.2.5 Electrical supply and electrodes

The electrical supply must be able to provide a virtually constant AC source voltage with a constant short-circuit current (symmetrical AC component) throughout a time interval equivalent to the arc duration. AC currents of 50 Hz and 60 Hz are permissible.

4.2.5.1 Electric test circuit

The electric test circuit shall be calibrated so that the test voltage and test current correspond to the voltage that would exist and the current that would flow under idle conditions if the electrodes were connected without impedance (short-circuit). Arc testing shall be carried out at this setting.

4.2.5.2 Test circuit control

The test voltage and test current shall be verified by measurement. The test current (prospective short-circuit current) shall be recorded in the form of an oscillogram of the instantaneous values. These should be depicted graphically.

The closing and opening of the electrical test circuit must be made with a circuit breaker that can be checked throughout the duration of the arc.

NOTE: *There are no specific requirements with respect to closing the electric circuit (related to the respective current sine wave angle) and the phase angle or the X/R ratio of the source impedance; if possible, the X/R ratio should lie within a range between 1 and 5.*

4.2.5.3 Electrodes

The electrodes must be made of copper (E-Cu) and aluminium rods (E-Al with $\geq 99.5\%$ Al or E-Al Mg Si 2.5) (refer to Fig. 5).

4.2.5.4 Fuse wire

A fuse wire connecting both ends of the opposing electrode tips shall be used to initiate the arc. This wire is consumed during the test. Therefore, its mass should be very small to reduce the burn risk due to molten metal. The fuse wire shall be made of copper with a nominal diameter of maximum 0.5 mm.

4.2.6 Electric test arc characteristics

The characteristics of the electric arc are defined by the following parameters:

Test voltage:	AC 400 V/+5 %
Test current/ _{Arc class} :	Class 1: 4 kA ± 5 % Class 2: 7 kA ± 5 %
Arc duration:	500 ms ± 5 %
Frequency:	Testing is to be carried out at a frequency of (50 ± 1) or (60 ± 0.12) Hz

During testing, these parameters must be compared so that the same parameters will be used for each test in a test series. The actual arc voltage and arc current shall be recorded throughout the duration of the arc for each test.

4.2.7 Data acquisition system

Measurement and data acquisition:

The system must be capable of simultaneously recording the current and the voltage in the electric the test circuit.

The sampling rate shall be at least 5 kHz.

The actual arc current and actual arc voltage shall be recorded for each arc test. These values should be graphically plotted in the protocol.

In addition to the voltage and current, the output values for both calorimeters shall be recorded. Temperature data shall be acquired at a minimum sampling rate of 50 ms/channel for at least 30 s.

4.2.8 Preparing the test specimen

4.2.8.1 The test head shall be attached to the torso so that it lies flush with the base of the neck and in such a manner that it will remain in position for the duration of the electric arc (refer to Fig. 7).

4.2.8.2 The face shield shall be pre-conditioned at a temperature ranging between 18 °C and 28 °C and a relative humidity between 45 % and 75 % for at least 24 h.

4.2.8.3 The face shield shall be set onto the test head in combination with the headgear prescribed by the manufacturer in accordance with the instructions in the User information.

4.2.9 Calibration

4.2.9.1 Measurement chain for temperature acquisition

The overall measurement chain, comprised of calorimeters and the data acquisition system, shall be calibrated on a regular basis.

For this, it must be possible to calibrate multiple temperature measuring points at levels above 100 °C. The data acquisition system must be calibrated. Due to the specific features of the testing process, it is recommended to check the calibration several times.

4.2.9.2 Calibration of the electric test circuit and performing the test

As verification of the test conditions, calibration oscillograms of the prospective adjusted test current and the test voltage shall be recorded for at least every test series with unchanged test parameters.

The reference measurement shall be carried out without the test specimen by measuring the direct incident energy E_{i0} .

It must be verified that the energy E_{i0} recorded for each sensor on the test panel lies within range of the double standard deviation $\pm 2 s$ around the mean value corresponding to Table 2, in accordance with DIN EN 61482-1-2, Fig. 3.

Test current	Mean value E_{i0}	Double standard deviation $\pm 2 s$
	kJ/m^2 (cal/cm^2)	kJ/m^2 (cal/cm^2)
Class 1: 4 kA	135 (3.2)	± 56 (1.3)
Class 2: 7 kA	423 (10.1)	± 78 (1.9)

Table 2: Statistically reliable mean value of direct incident energy

Electric arc energy values shall be determined for each individual test. A test is valid only if the arc energy W_{arc} lies within the range of the double standard deviation $\pm 2 s$ from the mean value corresponding to Table 3. Otherwise the test shall be repeated.

Test current	Mean value W_{arc}	Double standard deviation $\pm 2 s$
	kJ	kJ
Class 1: 4 kA	158	± 34
Class 2: 7 kA	318	± 44

Table 3: Permissible value of electric arc energy

4.2.9.3 Confirmation of test apparatus settings

The test apparatus setting shall be confirmed for each test. The measured values of arc current, arc duration, arc energy and arc voltage shall be recorded. A graph of the arc current shall be plotted in order to ensure proper phase response. Furthermore, the ambient temperature and relative humidity shall be recorded. The influence of wind or air currents must be prevented.

4.2.9.4 Preparing and conditioning the chamber

The chamber shall be prepared and conditioned prior to testing. The chamber should be configured according to Fig. 5. The chamber must be dry. The following preparation and conditioning instructions must be complied with prior to testing:

- The „plaster box“ shall be oven-dried at a temperature of approx. 60 °C for a period of 12 h. It shall be verified that the weight and the electrically-related surface resistance have not changed by more than 5 % at the end of the preparation process.

4.2.10 Maintenance and care of the test apparatus

4.2.10.1 Care of the sensor surface

The sensor surface should be wiped immediately after each test to remove any decomposition products that have collected and could cause future errors. If deposits collect and appear to be uneven or thicker than one coating of paint, then the sensor surface will require reconditioning. The cooled sensor should be carefully cleaned with an acetone or petroleum-based solvent that permits gentle treatment. The surface should then be coated with a thin layer of black, high-temperature paint. All sensors are to receive the same coating and it must be ensured that the surface is dry prior to beginning testing.

4.2.10.2 Care of the torso and test head

The torso and test head must be maintained in dry condition. When testing is conducted outdoors with extensive intervals between testing, the specimens shall be covered to prevent direct exposure to the sun and resulting excess temperatures.

4.2.11 Test procedures

4.2.11.1 Test apparatus

The test chamber, torso and test head shall be arranged according to Fig. 7.

4.2.11.2 Number of test specimens

Four prototypes of each type of face shield are required for testing.

The testing of electrician face shields used solely in conjunction with a safety helmet requires either two helmets with the minimum and maximum distances from the filter to the forehead (inner surface of the helmet sweatband), as prescribed by the manufacturer, or four safety helmets of a defined helmet type.

4.2.11.3 Test parameters

Test parameters are established for both of the following characteristic test categories:

Test category	Test current kA	Test voltage V AC	Arc duration ms
Class 1	4 ± 5 %	400 ± 5 %	500 ± 5 %
Class 2	7 ± 5 %	400 ± 5 %	500 ± 5 %

Table 4: Test parameters

4.2.11.4 Test conditions and initial temperature

Testing shall be carried out at an ambient temperature T_a between 15 °C and 35 °C with a relative humidity of 25 % to 75 %.

The initial temperature of the sensors must lie between 15 °C and 35 °C. The ambient temperature T_a and the initial temperature of the sensors T_o shall be measured. It must be ensured that the initial temperature of the sensors (when measuring the temperature difference by means of thermocouples) ranges within a tolerance of $T_o = T_a \pm 2 \text{ °C}$ for the test series. Decomposition products must be removed. The active surfaces on

the sensors should be reconditioned on a regular basis with a coating of black paint.

NOTE 1: *If necessary, the sensors should be cooled with an air jet or through contact with a colder surface. If condensed decomposition products are thicker than the paint coating, then the sensor should be cleaned with an acetone or petroleum-based solvent. The surface should be re-coated with a layer of black colour. The same colour should be used for all sensors.*

NOTE 2: *If outdoor testing requires suitable means to preclude the effects of wind, rain, etc., then the tests shall begin no later than 5 min from the time the specimen under test was removed from the pre-conditioning atmosphere.*

4.2.11.5 Performing the test

Electric arc shots are to be dispersed over the test specimen according to manufacturer specifications as follows:

- Four shots at the respective specific type of helmet
or
- Two shots each at the minimum and maximum distances from the inner surface of the helmet sweatband to the filter disc.

A new helmet should be used after each shot.

The arc shall be ignited within 5 minutes after removing the face shield from the pre-conditioning atmosphere.

The timing of arc ignition must be specified.

Temperature rise graphs are to be recorded for all sensors in the test series for the overall exposure time of 30 s.

The value pairs (maximum value of temperature rise ΔT_p at the point of time according to Table 5) are to be determined for each sensor.

4.2.11.6 Evaluation of measurement results

The incident energy shall be calculated by multiplying the maximum temperature rise by the sensor constant 5.52 kJ/m² °C (or 0.132 cal/cm² °C).

$$E_{io} = 5.52 \text{ (kJ/m}^2 \text{ °C)} \times \Delta T_{p,o} \text{ (°C)} \text{ or}$$
$$E_{io} = 1.132 \text{ (cal/cm}^2 \text{ °C)} \times \Delta T_{p,o} \text{ (°C)}$$

$$E_{it} = 5.52 \text{ (kJ/m}^2 \text{ °C)} \times \Delta T_p \text{ (°C)} \text{ or}$$
$$E_{it} = 1.132 \text{ (cal/cm}^2 \text{ °C)} \times \Delta T_p \text{ (°C)}$$

The direct incident energy E_{i0} and the four values of transmitted energy E_{it} shall be determined, as well as the mean value of the four E_{it} values and their corresponding 95 % margin of random error.

4.2.11.7 Test results

Once the electric arc has extinguished:

- the specimen afterflame time must not be greater than 5 s
- melting through of the specimen must not be evident
- holes or perforations in the specimen must not be evident
- the value pairs of all calorimeters on the test head must lie below the relevant values in Table 5.

Time to peak temperature value	Heat flow	Incident energy	Peak temperature value (corresponding calorimeter temperature rise)
s	kW/m ²	kJ/m ²	ΔT °C
1	50	50	8.9
2	31	61	10.8
3	23	69	12.2
4	19	75	13.3
5	16	80	14.1
6	14	85	15.1
7	13	88	15.5
8	11.5	92	16.2
9	10.6	95	16.8
10	9.8	98	17.3
11	9.2	101	17.8
12	8.6	103	18.2
13	8.1	106	18.7
14	7.7	108	19.1
15	7.4	111	19.7
16	7.0	113	19.8
17	6.7	114	20.2
18	6.4	116	20.6
19	6.2	118	20.8
20	6.0	120	21.2
25	5.1	128	22.6
30	4.5	134	23.8

Table 5: Resistance of the human tissue to heat; second-degree burns

4.3 Additional marking & identification

In addition to the visor panel markings in accordance with DIN EN 166, Sec. 9.2, the Electric arc class (1 or 2) and the VLT corresponding to Standard illuminant A (0 or 1 or 2) are to be indicated following the abbreviated specification of Resistance to electric arcing (8), separated respectively by hyphens.

Example: 8 – 1 – 0

The markings must agree with the values determined in Sections 4.1 and 4.2.

In addition, the product or the interchangeable components (as per the PPE Regulation, Article 3, 1b; e.g. visor panel) must be marked with the following information:

- CE marking and the subsequent identification number of the notified body involved in the process according to the PPE Regulation, Annex VII or VIII
- Manufacturer's or authorised representative's name, registered trade names or registered trademark and the postal address at which it can be contacted (if this is not possible, this information should be indicated on the packaging or on the accompanying PPE documentation)
- Type number, batch number or serial number, or other markings to serve as identification (if this is not possible, this information should be indicated on the packaging or on the accompanying PPE documentation)
- Month and year of manufacture and/or the month and year of expiry, if possible
- IEC 60417-6353 (2016-02) symbol – Protection against the thermal effect of the electric arc (Annex 1).

Test: Check the markings for completeness and plausibility.
Wipe test: Rub using two cotton cloths, one soaked in water and the other in isopropyl alcohol (CH₃-CH(OH)-CH₃) for 15 s each.
The markings must remain clearly legible following the test. It must not be possible to easily remove the marking labels, nor should they be wrinkled or creased.

4.4 User information

In addition to the information required according to DIN EN 166, Sec. 10, the following information must be provided:

- Detailed information related to safety helmets that may be used in conjunction with the electrician face shield:
 - ◆ Electrician's helmet (e.g. In accordance with DIN EN 50365)
 - ◆ Minimum and maximum distances from the filter to the forehead (inner surface of the helmet sweatband) or the helmet type designation

NOTE: *Minimum/maximum distances from the filter to the forehead are considered in the test according to Sec. 4.2.*

- Explanation of the scope of application
- Explanation of the abbreviation for the electric arc class and the electric arc symbol in accordance with Annex 1
- Explanation of the abbreviation for Visible light transmittance in accordance with the classification according to Sec. 4.1.1
- With LT classes 0, 1 or 2, additional information is required in accordance with Annex 2 corresponding to the class specified by the manufacturer.
- The risk, against which the PPE is intended to protect.
- If the product is not accompanied by the EC Declaration of Conformity, but it can be obtained via the Internet, then the following information must be provided in the User information:
 - The location where this regulation can be found and, if applicable, the location where the other Union harmonisation legislation can be found.
 - The name, address and identification number of the notified body or bodies involved in the PPE conformity assessment process.
 - The location where the applicable harmonised norm(s), including their respective date(s), or other technical specifications applied can be found.
 - The Internet address at which the EC Declaration of Conformity can be found.

4.5 External materials

No materials containing substances harmful to health may be used on any part of the electrician face shield that could come in contact with the wearer's skin.

Test: Review of the safety data sheets for relevant materials, as well as the manufacturer's declarations related to material content and compliance with prescribed limit values.

4.5.1 Plastic components

That proportion of polycyclic aromatic hydrocarbons (PAH) used in that part of the electrician face shield that can come in contact with the operator's skin must not reach a level that could be harmful to health.

NOTE: *Further examinations may be necessary on an individual basis if there is cause for doubt.*

Test: Test of critical components according to the German AfPS GS 2014:01 PAK. (Also refer to the REACH Regulation, No.1907/2006, Annex XVII).

4.5.2 Textile/leather components

Auxiliary components made of textile or leather materials must not contain substances that could be harmful to health.

Test: The manufacture declares compliance with the limit values for relevant content or treatment substances, such as dimethyl fumarate (DMF) or chromium VI with leather products (Also refer to the REACH Regulation, No.1907/2006, Annex XVII).

NOTE: *Independent verification related to harmful substances could be provided (e.g. through OEKO-TEX®).*

4.6 Test setups

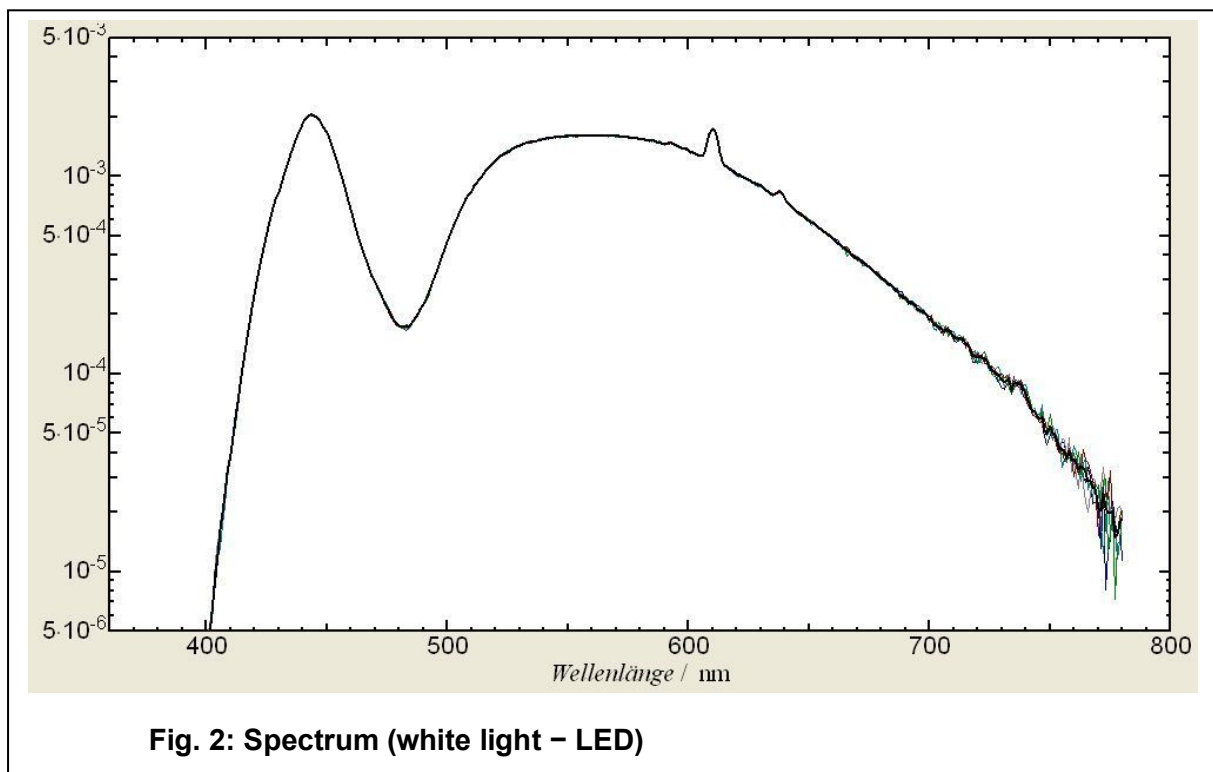
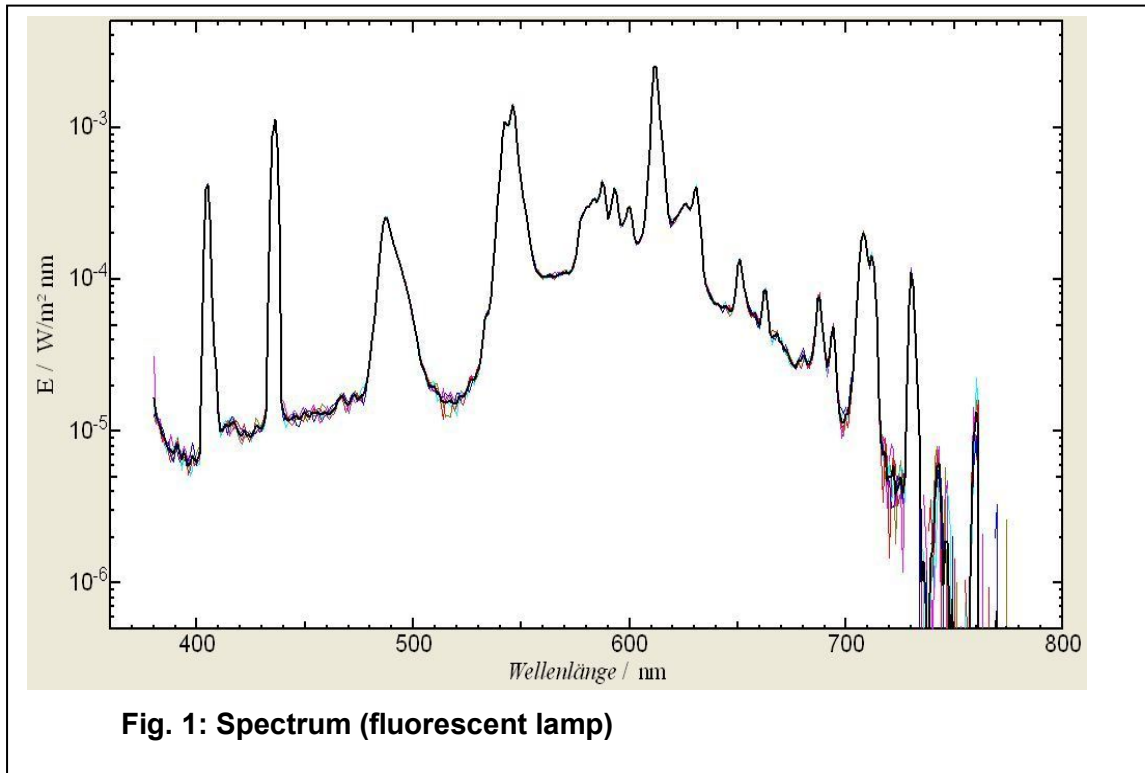

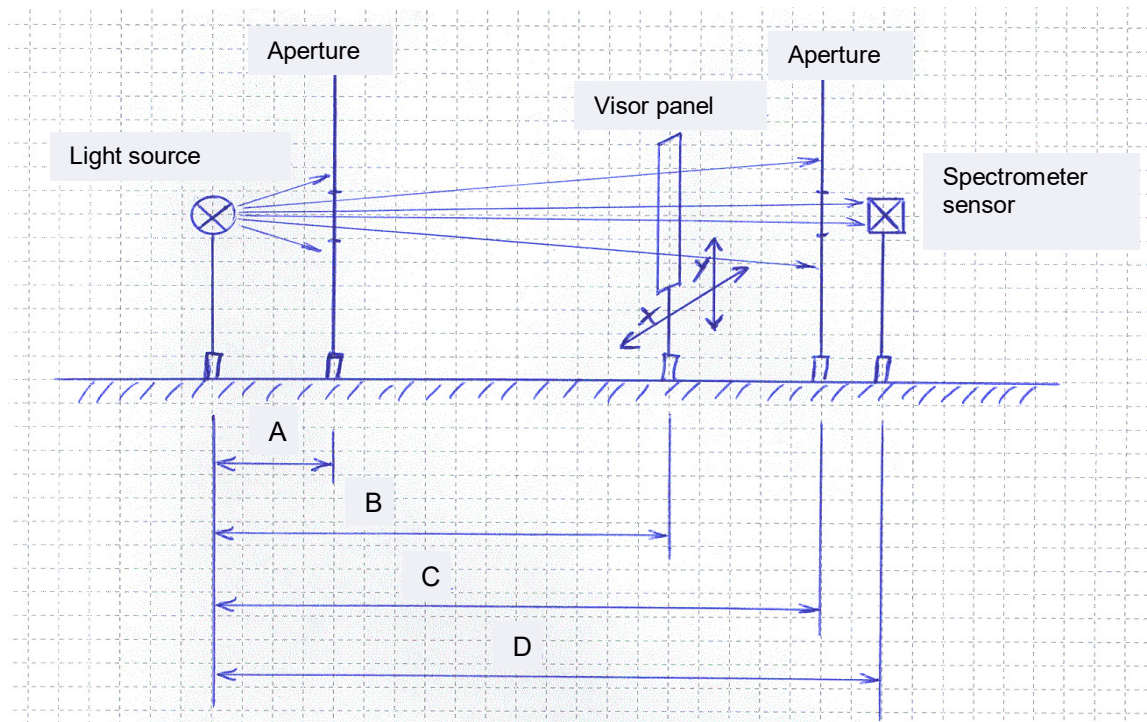

Fig. 3: Setup for determining Visible light transmittance

When using illuminant A

(Standard illuminant A according to DIN EN ISO 11664-2):

- * D > 20 times the filament diameter, at least 1 m
- * B $\approx \frac{2}{3}$ of D
- * A and C are to be positioned in such a manner that reflections will not be produced on the sensor

When using fluorescent light

(typically: daylight spectrum, Brand: OSRAM, Type: L/827; refer to Fig. 1):

- * D minimum 0.75 m
- * B $\approx \frac{2}{3}$ of D
- * A and C are to be positioned in such a manner that reflections will not be produced on the sensor

When using LED light

(typically: Brand: LINUS, Type: Luxion STAR 065150000 with condenser and diffusing disc; refer to Fig. 2):

- * D minimum 0.5 m
- * B $\approx \frac{1}{2}$ of D
- * A and C are to be positioned in such a manner that reflections will not be produced on the sensor (Aperture stop 1 can be dispensed with, if necessary!)

Once chosen, the distances must be documented and will remain binding for the entire measurement series.

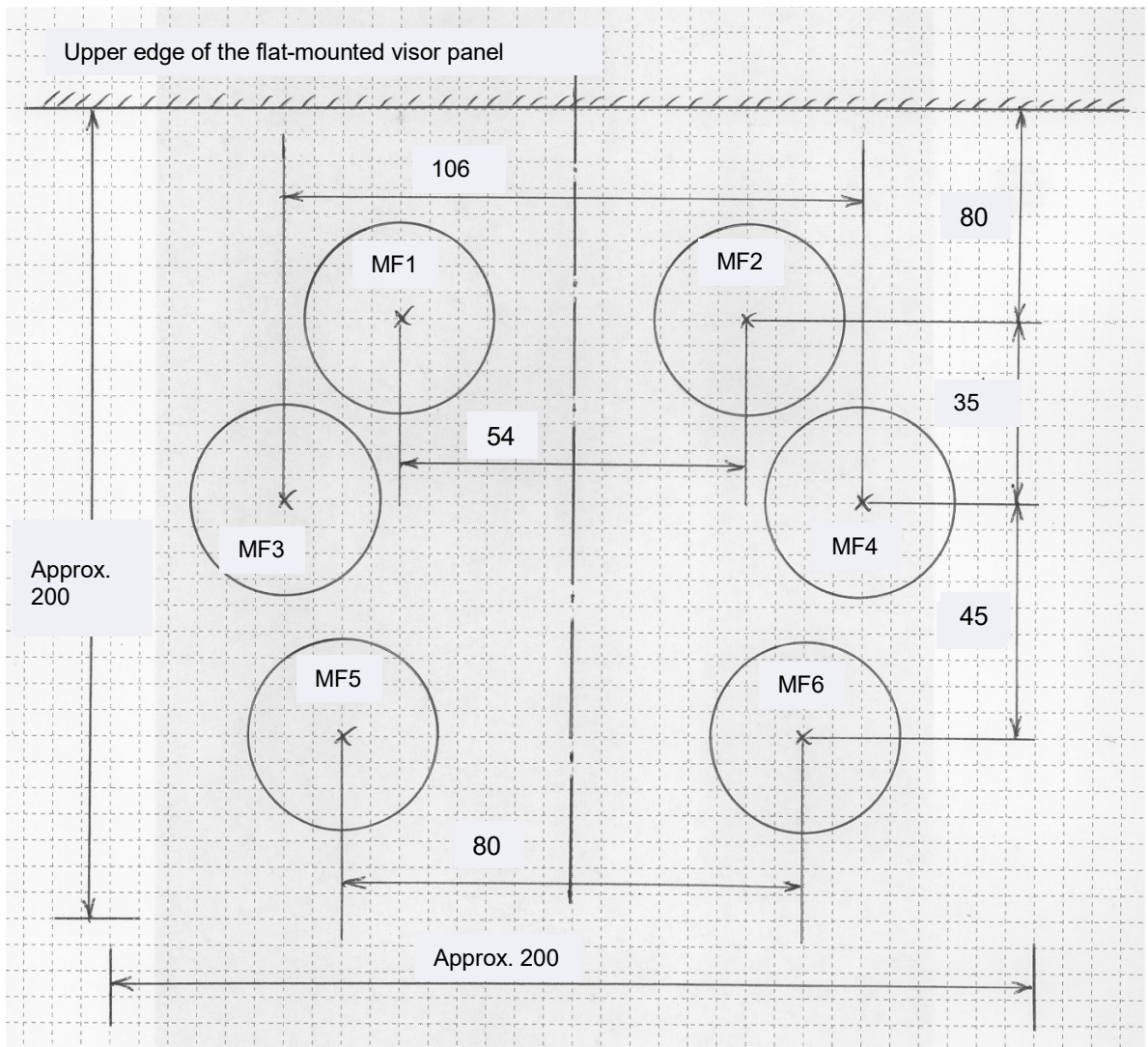

Fig. 4: Measuring field (dimensions in mm)

Dimensions in mm

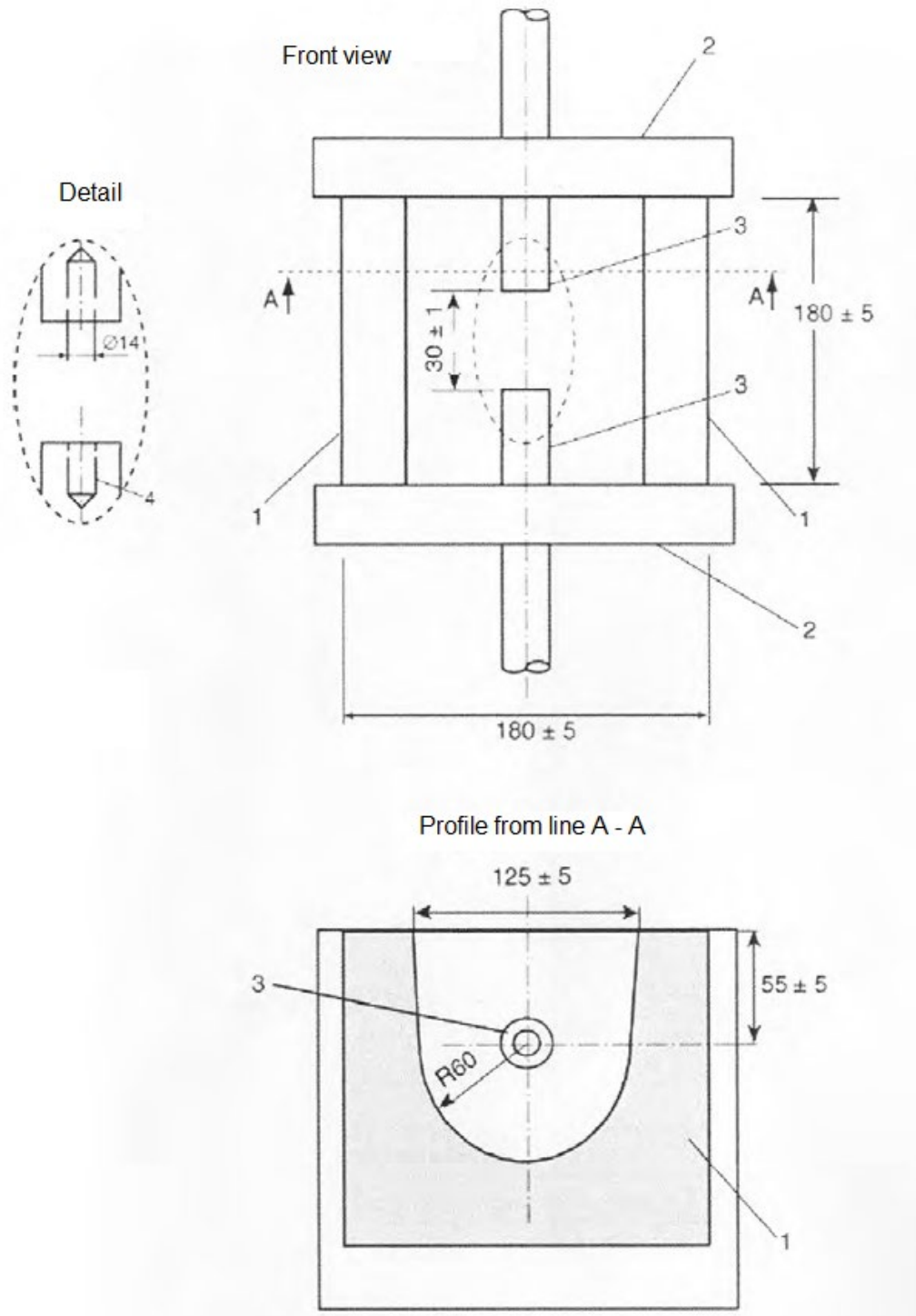

Fig. 5: Test chamber

Legend

- 1 Non-conductive, heat-resistant material (e.g. plaster box)
- 2 Insulating plate, thickness > 15
- 3 Electrodes $\varnothing 25$ (upper side aluminium, lower side copper)
- 4 Bore holes $\varnothing 14$, Depth = 20

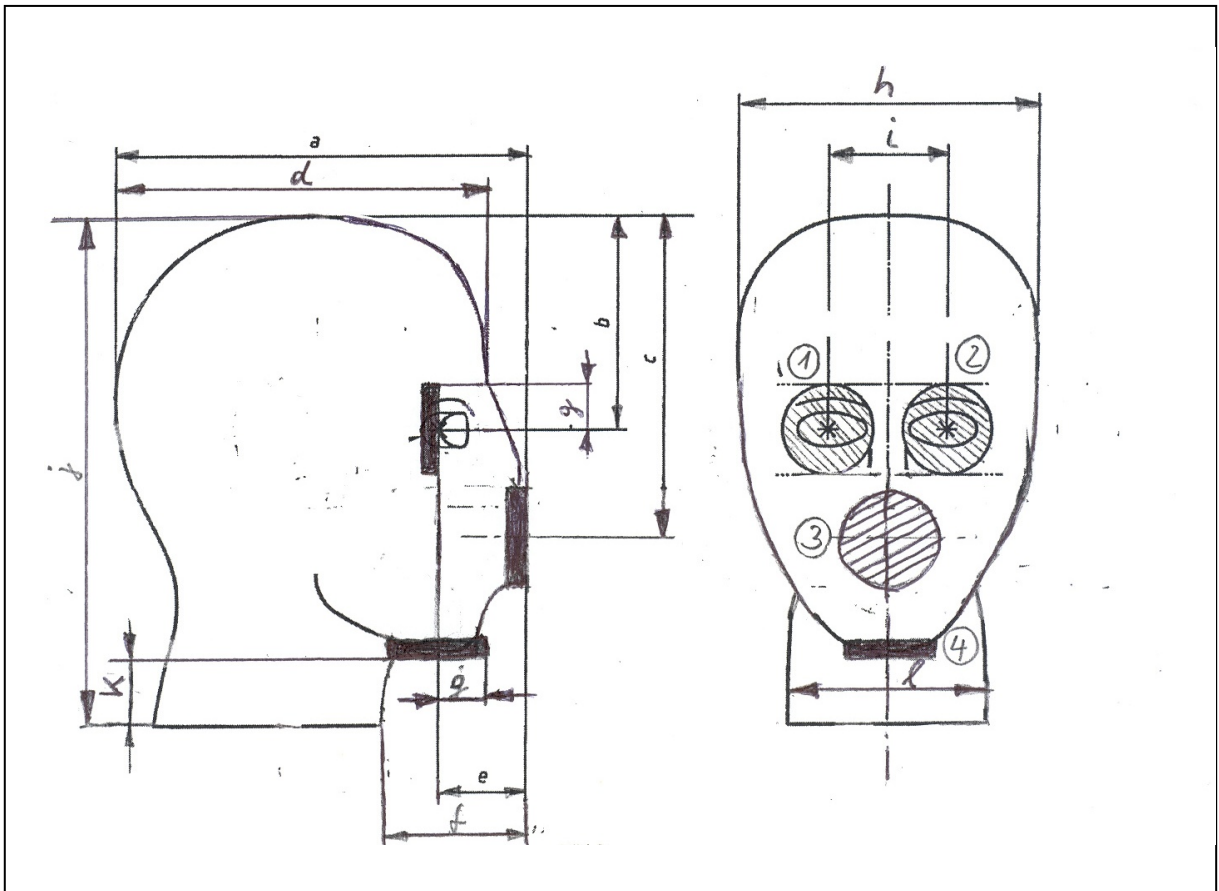

Fig. 6: Test head

Dimensions in mm; Tolerance: ± 1.5

Dim.	Values [mm]
a	218
b	111
c	175
d	200
e	35
f	93
g	30
h	160
i	80
j	261
k	35
l	105

NOTE: Any undefined head dimensions can be freely selected but should be oriented on the 50th percentile of adult males.

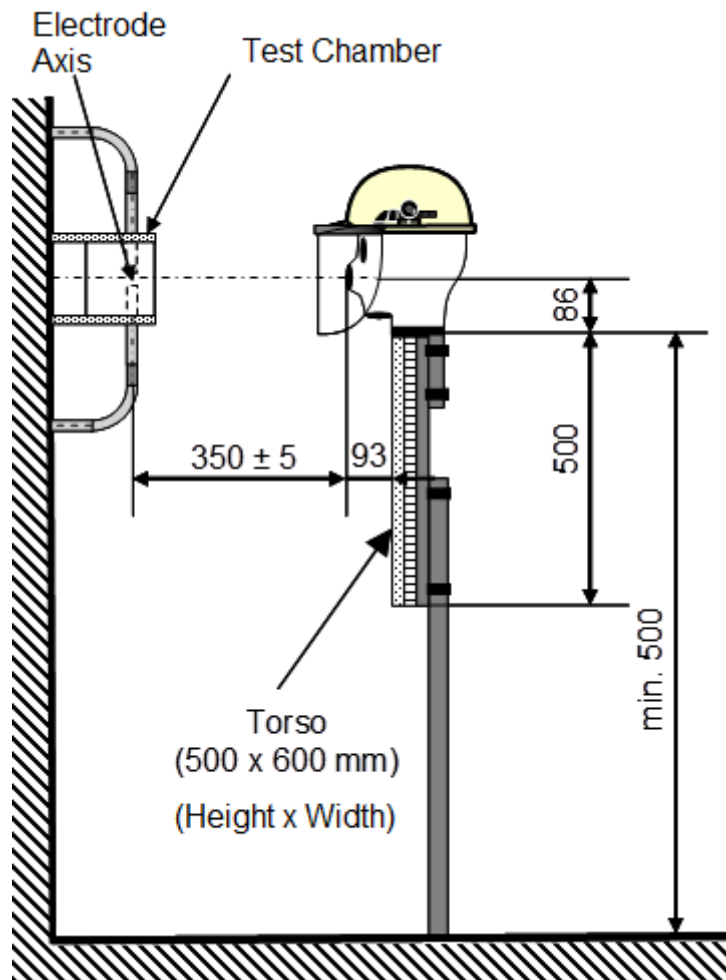

Fig. 7: Test apparatus (dimensions in mm)

Annex 1

Symbol as per IEC 60417-6353 (2016-02) –
Protection against the thermal effect of the electric arc

Annex 2:

Light transmittance class 0:

„This product is assigned to the highest Light transmittance class 0 (LT Class 0). Under normal working conditions no additional lighting is required. However, please check your ability to detect color in the work environment before using this product. “

Light transmittance class 1:

„This product is assigned to Light transmittance class 1 (LT Class 1). Additional lighting is not required under normal working conditions. In any case, check your ability to detect color in the work environment before using this product. “

Light transmittance class 2:

„This product is assigned to Light transmittance class 2 (LT Class 2). Additional lighting is required under normal working conditions. In any case, check your ability to detect color in the work environment before using this product. “

Furthermore, the following information should be included in the User information:

„Artificial lighting can interfere with the tint of the face shield and impair colour perception, especially when using fluorescent or LED lamps as illuminants. It must be ensured that all cable codes used at the workplace can be safely distinguished under actual lighting conditions.

Check your colour perception prior to starting work by performing the following steps:

- 1. Gather a sampling of cable pieces having the same colour coding as the cables used at your workplace.*
- 2. Ensure that you are in a safe location, but with the same lighting (type and intensity) as anticipated at your workplace.*
- 3. Clean the face shield and check it for damage (do not hesitate to replace the face shield if necessary - refer to the User information).*
- 4. Don the face shield as described in the User information.*
- 5. Quickly sort through the bundled cable samples.*

If you have difficulty distinguishing between the various cable codes or are mistaken in sorting them, then the lighting is insufficient and/or the face shield is too dark. This could cause an accident at work, such as electric fault arcing.“

Annex 3

 <p>DGUV Test Prüf- und Zertifizierungsstelle Fachausschuss Elektrotechnik</p>	<p>Specifications for contract preparation</p> <p>- Face shields for electrical work -</p>	<p>Company:</p>
--------------------------------------------------------------------------------------------------------------------------------------------------------------------------------------	----------------------------------------------------------------------------------------------------------	-----------------

Product identification information

Product nomenclature

Type

Product variants available? Yes / No

Variant matrix attached? Yes / No

Information regarding test specifications and parameters

Testing in accordance with DIN EN 166 with optional requirements:

1. _____
2. _____
3. _____
4. _____
5. _____

Documentation to be submitted	<i>attached</i>	<i>will be submitted</i>
User information	<input type="checkbox"/>	by
Sales literature	<input type="checkbox"/>	by
Engineering drawings	<input type="checkbox"/>	by
Parts list(s)	<input type="checkbox"/>	by
Data sheets	<input type="checkbox"/>	by
Internal work instructions/Test protocols	<input type="checkbox"/>	by
Risk assessment	<input type="checkbox"/>	by

Declaration of Conformity	<input type="checkbox"/>	by
Documentation to be submitted	<i>attached</i>	<i>will be submitted</i>
Selection of control measures (Module C2 or D, according to the PPE Regulation) with information regarding the implementing body	<input type="checkbox"/>	by
Written declaration that the application for EC type-examination, or appropriate control measures if applicable, has not been submitted to another notified body	<input type="checkbox"/>	by
Test reports provided by external accredited test bodies for...	<i>attached</i>	<i>will be submitted</i>
Thermal protection for electric fault arcs	<input type="checkbox"/>	by
_____	<input type="checkbox"/>	by
_____	<input type="checkbox"/>	by

Note: In the interest of prompt order processing, it is essential that the information above be provided in its entirety!

Date

Name

Signature